

Basic compost bin construction

3-bin System

The 3-bin system requires a minimum 3' x 9' of yard space. This system is excellent for hot composting with removable front slats for easy turning, and separate bins for turning and aging compost, and/or storing compostables. Large amounts of compost can be produced using this bin. Carpentry skills needed for construction. Budget \$250 to \$300 for new materials, or better yet, use salvaged materials.

MATERIALS

- 2 x 4" wood: 31 1/2" (8), 36" (8), 9' (4), and 29" (4)
- 2 x 6" wood: 36" (4)
- 2 x 2" wood: 34 1/2" (6), 9' (1), and 29" (4)
- 1 x 6" wood: 31" (19)
- 1/4" mesh hardware cloth: 30' x 3'
- Carriage bolts: 3 1/2" x 3/8" (12), with washers and nuts
- 12 penny galvanized nails (2 lbs.)
- 8 penny galvanized nails (1 lb.)
- Poultry wire staples (1 lb.)
- Corrugated fiberglass: 4 oz. 8' x 26" (2)
- Gasketed roofing nails: (40)
- Wiggle molding: 18'
- 3" hinges, zinc plated, galvanized or brass (3)
- 4" flat corner braces with 1" wood screws (4)
- 4" flat T-braces with 1" wood screws (4)
- Hook eyes (4)
- Light cable or chain: 8'

TOOLS

Power saw or hand saw, drill with 3/8" and 1/16" bits, screwdriver, hammer, tin snips, tape measure, pencil, socket or wrench, carpenter's square. Use proper eye, ear and body protection.

ASSEMBLY

Main Structure

Nail two 31 1/2" and two 36" 2 x 4s together with 12 penny nails to form each of four screen dividers. Cut four 36 x 33 1/2" wire mesh pieces, and staple every four inches to frames after checking frames for squareness. Bolt dividers to three 9' 2 x 4s as shown. Inside measurement between dividers should be 31 5/16". Nail 29" 2 x 4s as shown. Staple one 9' x 3' piece of wire mesh every four inches to back of structure, and one 9' x 3' piece to the bottom.

Slats and Slat Tracks

Nail 2 x 6s to front of dividers. Nail 34 1/2" 2 x 2s onto frames as shown. Leave at least one inch for the slats to slide in. The last slat of each bin section may need to be cut lengthwise to fit.

Lid

Assemble lid frame as shown with flat corner and T-braces on the bottom side. Pre-drill nail holes every couple of feet into wiggle molding humps, and attach molding to 9' 2 x 2s and 9' 2 x 4 with 8 penny nails. Cut fiberglass into five 32" pieces with tin snips. Pre-drill fiberglass and wiggle molding on top of every third hump, and nail together with gasketed nails. Be sure to overlay fiberglass pieces at least one channel wide. Trim off excess fiberglass before attaching the last piece. Attach lid to frame with hinges. Attach light cable or chain to lid and main frame with hook eyes as shown to prevent lid from overextending.

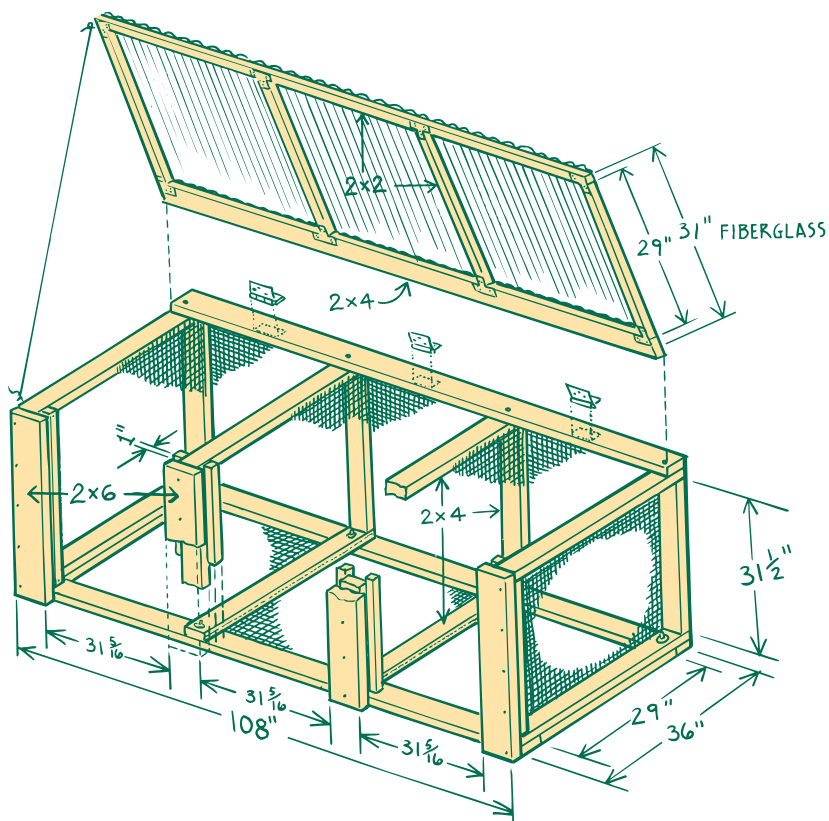

METRO

Printed on recycled content paper.
30 percent post consumer waste .07356

Basic compost bin construction

Wood and wire compost bin

Use this bin for basic "Add as You Go" or "Batch" composting. The bin has two front doors for easy harvesting and turning, a top that doubles as a sifter, and a full wire mesh lining. Small to large amounts of compost can be produced. Carpentry skills are needed for construction. Budget \$150 to \$200 for new materials, or better yet, use salvaged materials.

MATERIALS

- 1 x 6" wood: 8' (8)
- 2 x 4" wood: 8' (2)
- 2 x 4" wood: 10' (1)
- 1 x 4" wood: 6' (3)
- 1/4" wire mesh hardware cloth: 15' x 3'
- 5" drawer handles (4)
- 1 1/2" hooks and eyes (8)
- 4" corner brackets with 1/2" wood screws (8)
- Solvent-free, low VOC, waterproof wood glue
- 8 penny galvanized nails (20+)
- 6 penny galvanized nails or screws (125+)
- 3/4" poultry wire staples (250+)

TOOLS

Power saw or handsaw, screwdriver, hammer, measuring tape, pencil, square, drill with 1/16" bit, sandpaper.

Use proper eye, ear and body protection.

ASSEMBLY

Glue all wood pieces before nailing.

1. Nail 2 x 4 bottom frame together with the larger nails. Be sure the finish dimension is 30 1/2 x 31 1/4".
2. Build sides by nailing bottom and top 31 1/4" 1 x 6s to the 2 x 4s (use smaller nails). Be sure bottom 1 x 6s hang down 3 1/2" below 2 x 4 uprights. Fill in the remaining 1 x 6s equally spaced, with no gaps larger than 1/4".
3. Attach sides to base by nailing 3 1/2" overhang to base as drawn (with smaller nails). Nail 2 x 4 uprights into bottom frame with larger nails.
4. Nail the six 32" 1 x 6s to back by first attaching the top and bottom pieces, then filling in the remaining four, spaced equally.
5. Before cutting pieces for the front doors, measure the actual opening at the front of the bin, and make sure to cut the 1 x 6s just 1/8 to 1/4" smaller than the opening. Build top door by nailing three 1 x 6s to the two 17" 2 x 4s with 1/4" between each board as shown. Build bottom door by first nailing on the top two 1 x 6s (1/4" apart), then measuring the remaining space, and cutting the last 1 x 6 lengthwise to fit.
6. Attach eyes to front 2 x 4 uprights, and hooks to front doors as drawn.
7. Build lid by pre-drilling and tacking together as drawn using smaller nails. Make sure the finished outside dimension is 35 x 35" and is square. Then pre-drill and screw the corner brackets to the inside corners, and the top 1 x 4s into place. Cut a 33 x 36" piece of wire screen and staple it to the inside of the lid.
8. Cut remaining screen to fit. Staple side, back and door pieces inside bin on 1 x 6s (not over 2 x 4s). Staple bottom piece onto the underside of bin.

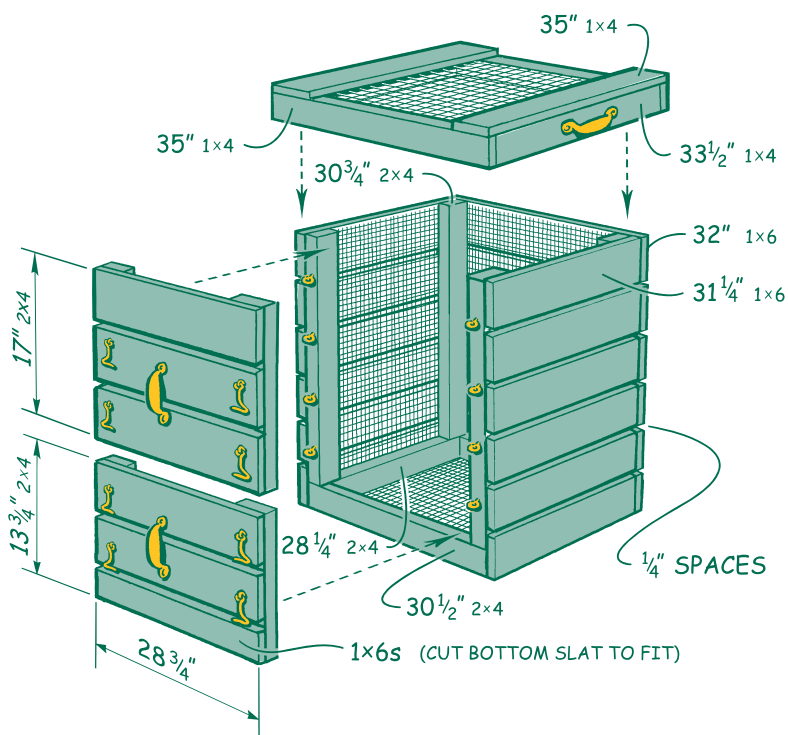

METRO

Printed on recycled content paper.
30 percent post consumer waste .07356